

# 5 Dimensional drawings

## 5 - 1 Dimensional Drawings

### RXA42B9

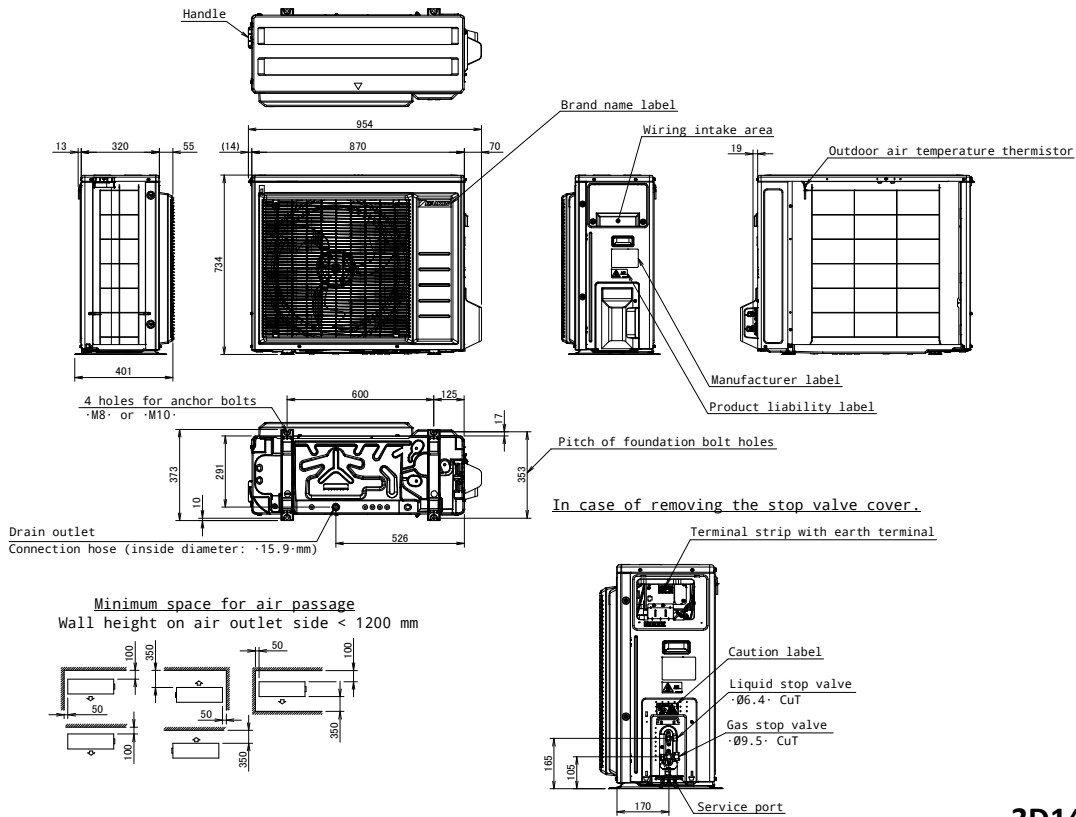

**3D145176**

### RXA50B

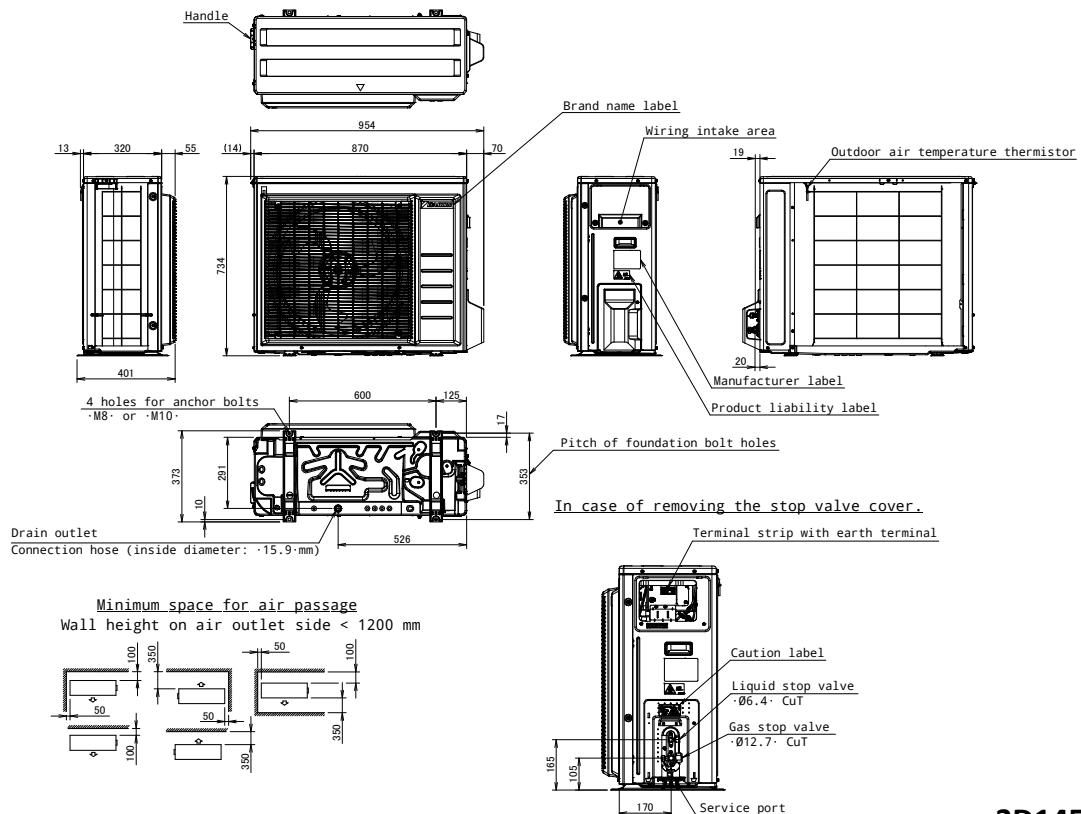

**3D145182**