

Unit: mm

MUZ-LN60VG
 MUZ-FH50VE
 MUZ-SF50VE
 MUZ-GF60VE
 MUZ-GF71VE
 MUZ-AP71VG

OUTDOOR UNIT

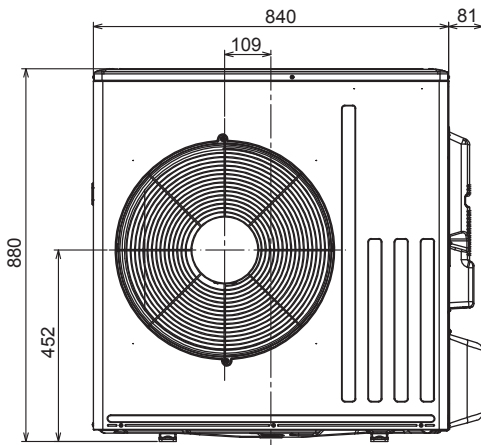
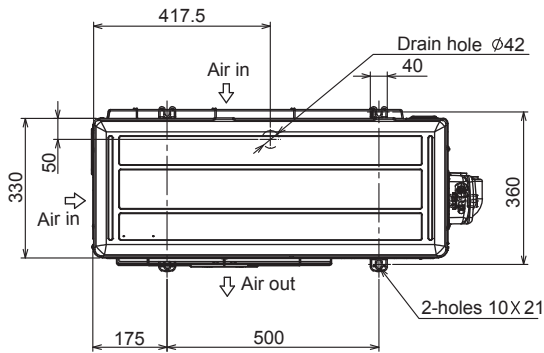

REQUIRED SPACE

*1 500 mm or more when front and sides of the unit are clear

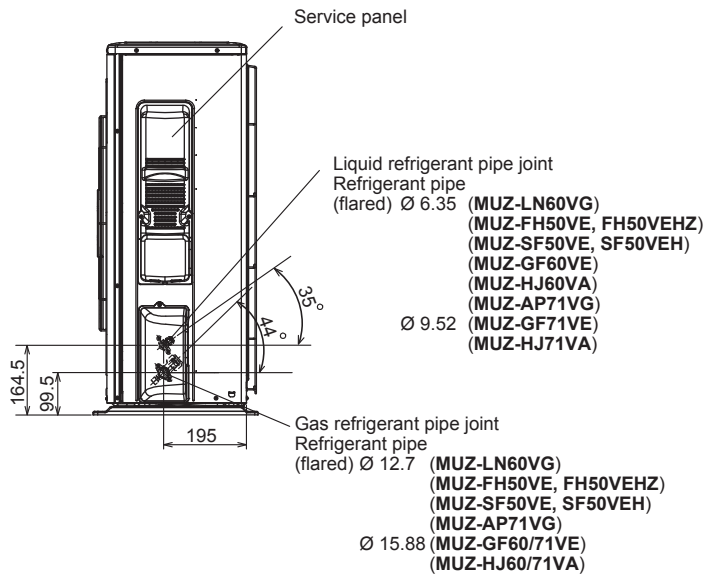
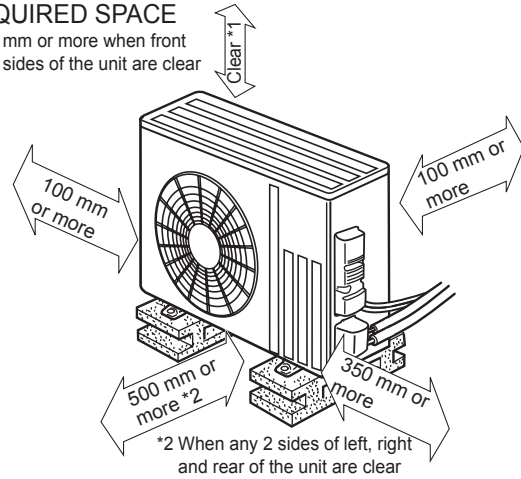

OUTLINES AND DIMENSIONS WALL-MOUNTED