

# Dimensional drawings

## Outdoor Units

2.6 kW/3.5 kW Outdoor Unit

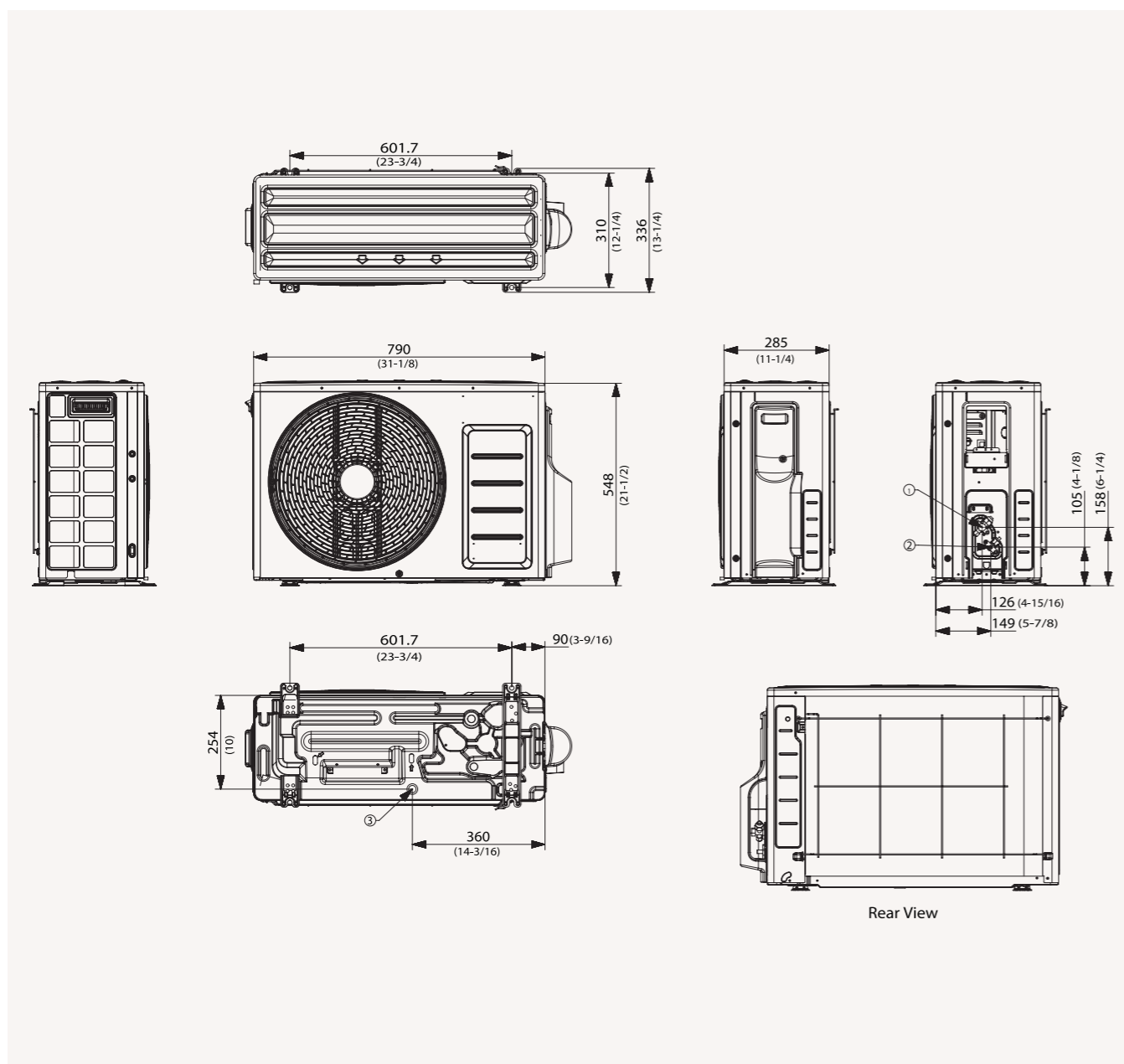

| NO | Name                    | Description                              |
|----|-------------------------|--|
| 1  | Refrigerant gas pipe    | ø9.52 (3/8)                              |
| 2  | Refrigerant liquid pipe | ø6.35 (1/4)                              |
| 3  | Drain hole              | Connection with the provided drain plug. |

5.2 kW/6.0 kW Outdoor Unit

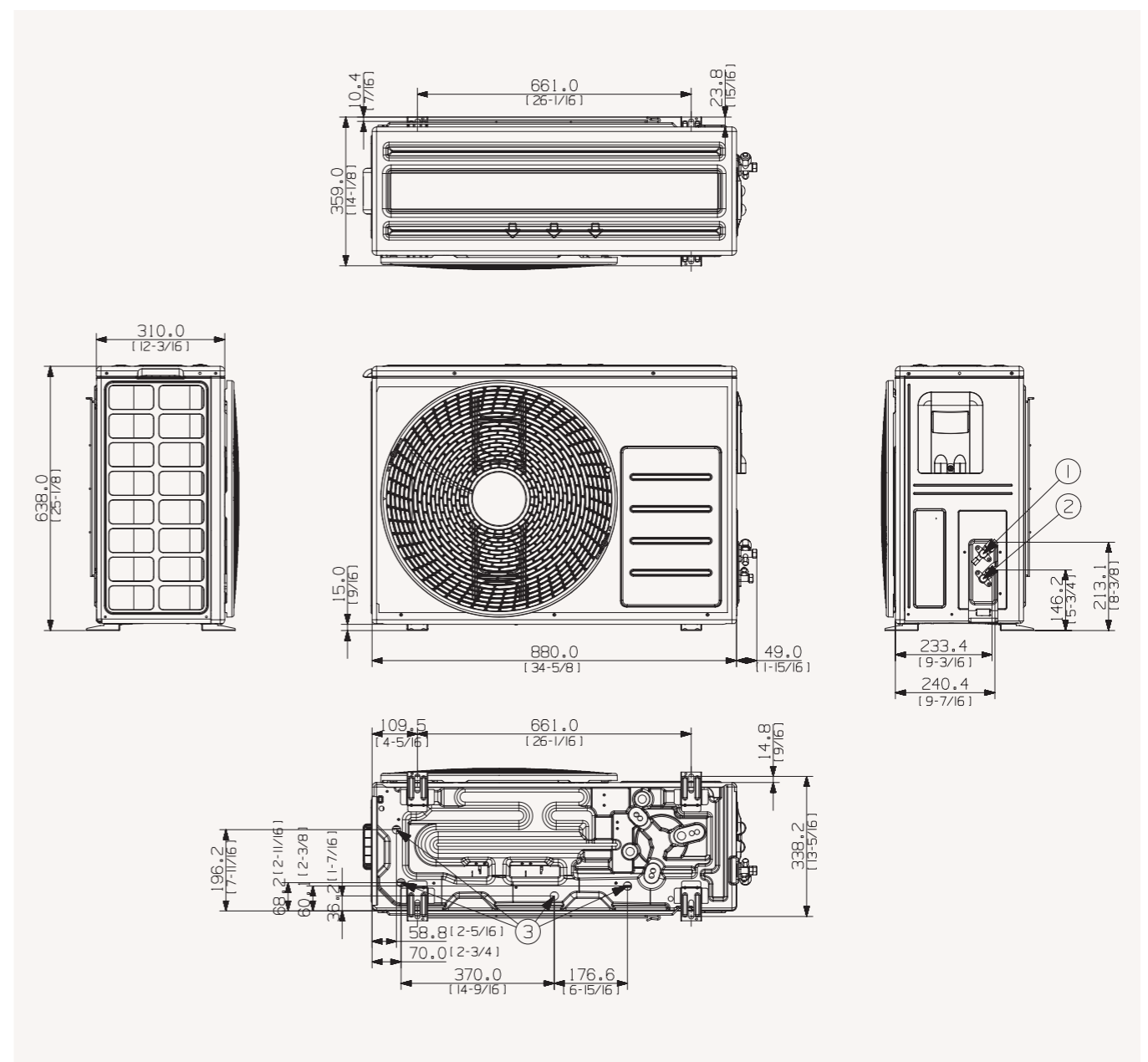

| NO | Name                    | Description  |
|----|-------------------------|--------------|
| 1  | Refrigerant gas pipe    | ø12.70 (1/2) |
| 2  | Refrigerant liquid pipe | ø6.35 (1/4)  |
| 3  | Drain hole              | ø20          |