

Dimensional drawings

Outdoor Units

7.1 kW Outdoor Unit

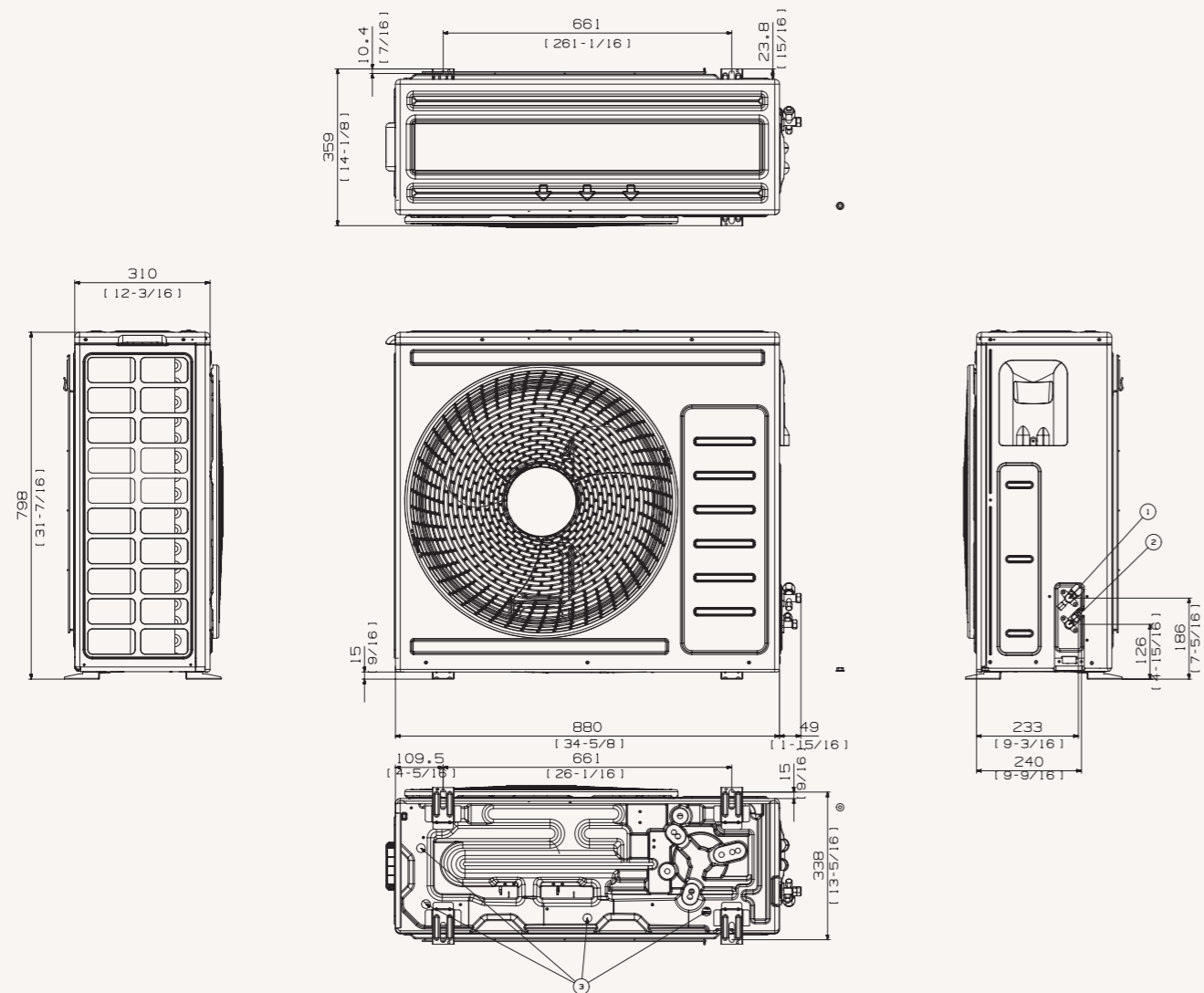

NO	Name	Description
1	Refrigerant gas pipe	ø15.88 (5/8)
2	Refrigerant liquid pipe	ø6.35 (1/4)
3	Drain hole	Connection with the provided drain plug.

9 kW/10 kW/12 kW Outdoor Unit

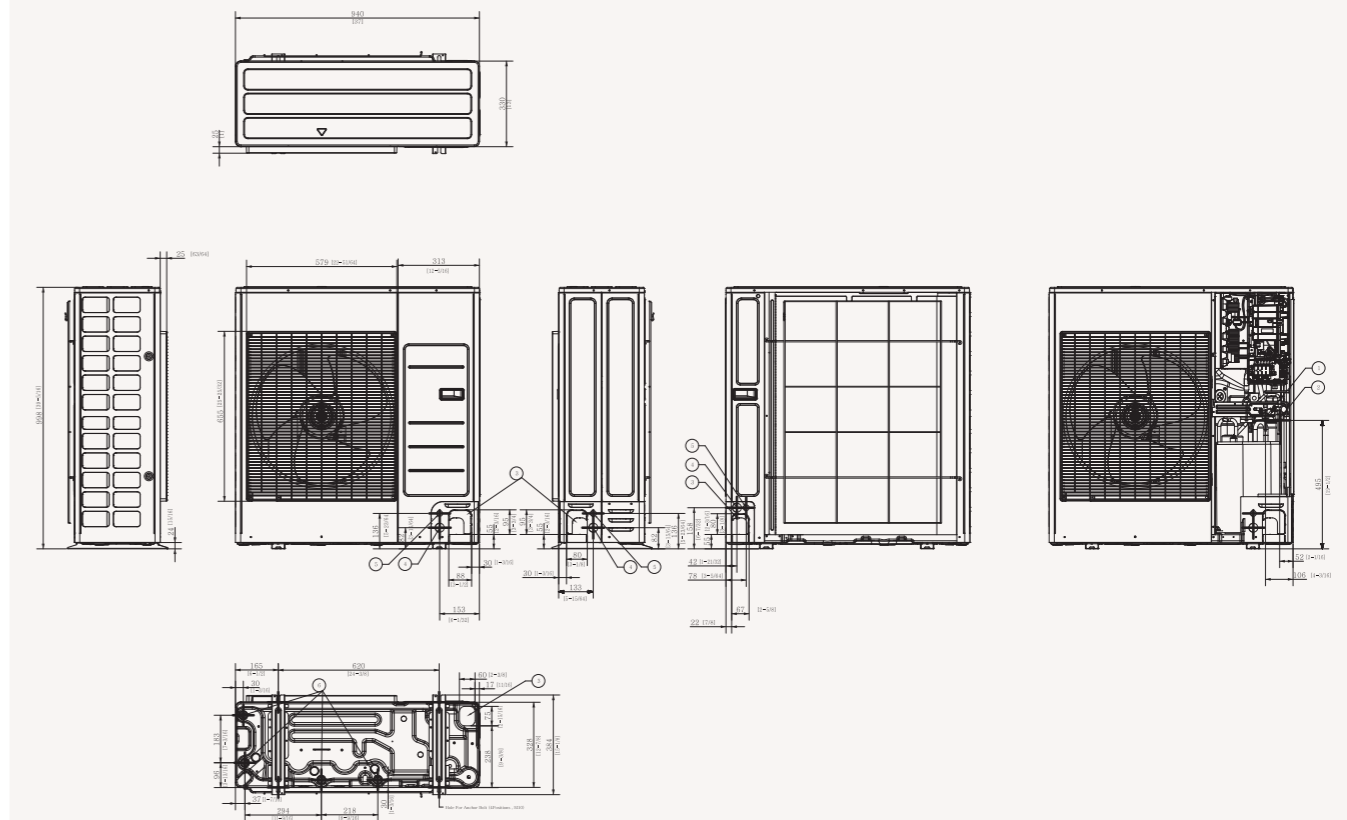

NO	Name	Description
1	Liquid pipe connection	ø9.52 (3/8)
2	Gas pipe connection	ø15.88 (5/8)
3	Piping intake knock-out hole	Front/Side/Rear/Bottom
4	Power wiring conduits	Front/Side/Rear, ø34 (ø1 3/8)
5	Communication wiring conduits	Front/Side/Rear, ø22 (ø7/8)
6	Drain hole	Connect with the provided drain plug.